

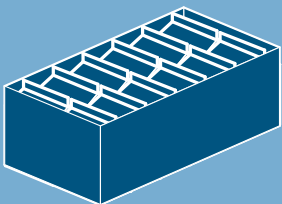

Versapack

Compact case erecting and packing system

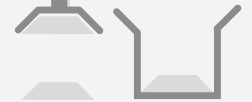

VERSAPACK™

COMPACT CASE ERECTING AND PACKING SYSTEM

Versapack™ is the smallest and fastest integrated case erecting and packing machine on the market with the ability to pack products in almost any orientation including 'on-edge'.

Based on a new fast robotic case erector and the Quin revolutionary Rtheta™ high speed picking head, the Versapack™ provides outstanding performance in the automation of end of line packaging.

- Packs multiple products including cartons, trays, roll-wraps, flow-wrap packs, flexible packs, bottles, bags and pouches.
- Ideal for shelf ready display with ability to pack products flat or 'on-edge'.
- Compact footprint of approximately 2.6 m x 2.3 m.
- High speed pick and place, typically 70 cycles per minute with 2kg load.
- Typically 70 to 200 products/min.
- Flexibility to provide packing formats with multiple rows, columns and layers.
- Wide range of cases (including narrow 80mm cases) packed at 20+ cases/min.
- Payback within 12-18 months.



PACKING FORMATS

The Versapack™ is suitable for a wide range of packaging formats including regular slotted cases (RSC) and shelf-ready packaging (SRP).

Flow-wrapped packs

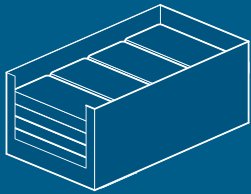

Roll-wrap packs

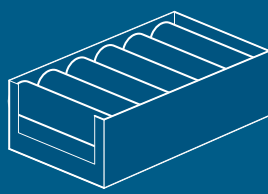

Cartons

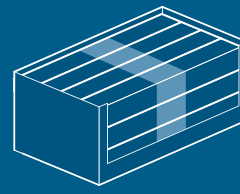

Bottles

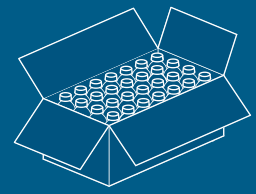

On-edge shelf ready

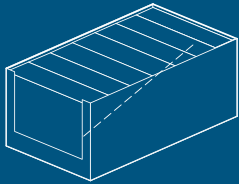

Bags/packs packed on edge

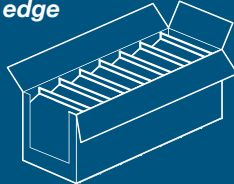

Multiple columns of packs packed on edge

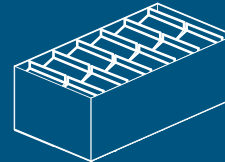

Trays packed on-edge

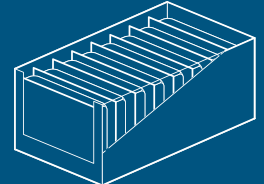

TYPICAL LAYOUT

Dimensions in mm

OPTIONAL LAYOUTS

- Reverse flow
- In-line
- 90° feed

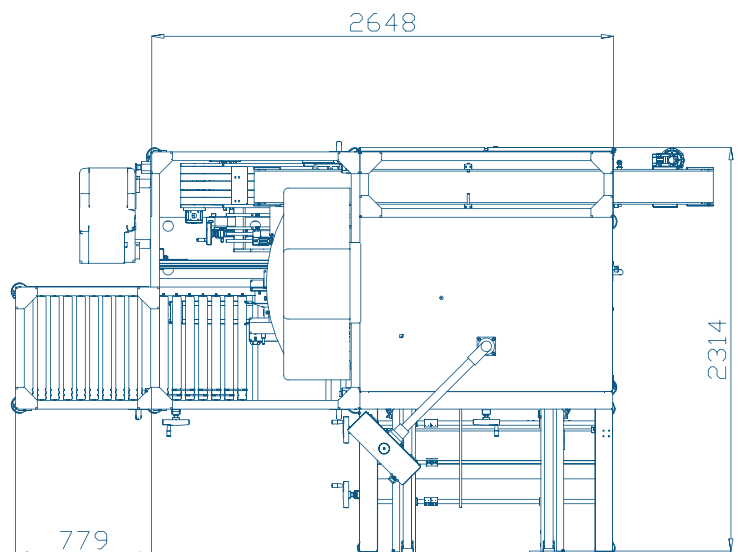

We are always happy to discuss your applications and answer your questions.

Telephone: +44 (0) 118 977 1077 www.quin.co.uk email: sales@quin.co.uk